

# Flygt 2075.324

DEWATERING PUMP

50 Hz

## Tough pumps for dewatering

The Flygt dewatering pumps from Xylem are designed for tough operating conditions. The pumps are ideal for applications in which the water or liquid contains high amounts of clay, stone chips, drilling fines etc, or to pump heavy sediment from tanks, sumps and containers.

This cast iron dewatering pump is designed for heavy-duty application in which the liquids are corrosive, abrasive or contains salt water.

Our dewatering pumps are backed by an outstanding support and world-wide presence. Operating in over 150 countries, we bring many years of experience to bear in order to keep your business moving.



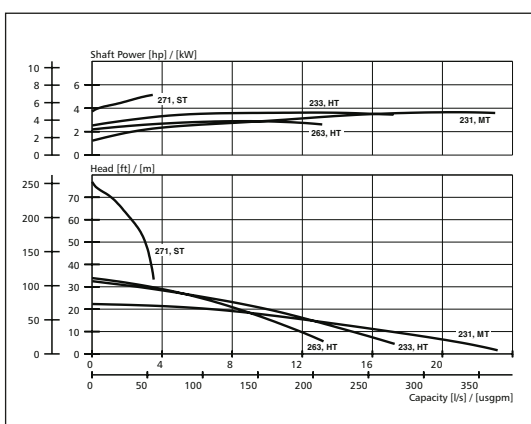
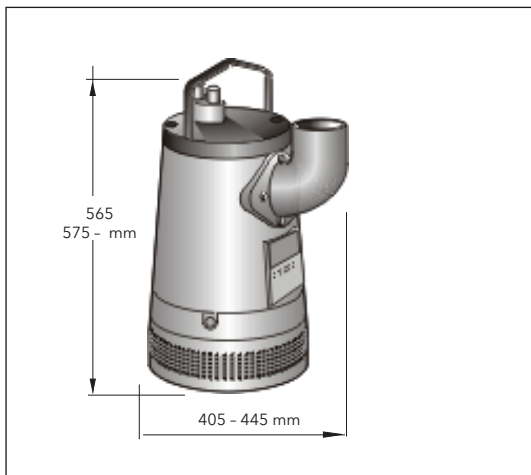

* 3~ Voltage (V)	Rated current (A)	Starting current (A)
200	14.0	83
220	13.0	59
380	7.5	34
440	6.5	33
500	5.7	26
550	5.2	29

** 3~ Voltage (V)	Rated current (A)	Starting current (A)
220	21.0	107
380	12.5	59
440	11.5	56
500	9.4	46
550	8.4	55

## Product

Submersible pump for dewatering building yards, draining water in flooded areas, and other similar applications. The pump can handle water containing relatively abrasive solids.

## Denomination

Product code	2075.324
Installation	S
Impeller characteristics	MT, HT, ST
Discharge connection	2", 3", 4"

## Process data

Liquid temperature	max +40 °C
Depth of immersion	max 20 m
The pH of the pumped liquid	pH 5.5 - 14
Liquid density	max 1100 kg/m <sup>3</sup>
Strainer hole size	8 mm x 8 mm

## Motor data

Squirrel cage 3-phase induction motor.	
Frequency	50 Hz
Insulation class	F (+155° C)
Voltage variation	
- continuously running	max ± 5%
- intermittent running	max ± 10%
Voltage imbalance between phases	max 2%
No. of starts/hour	max 15

## Monitoring equipment

Thermal contacts

## Cable

Direct-on-line and Y/D start	SUBCAB®
------------------------------	---------

## Material

Outer casing	Cast iron
Impeller	Spring steel
Wear parts lining	Nitrile rubber
Stator housing	Cast iron
Strainer	Stainless steel
Shaft	Stainless steel
O-rings	Nitrile rubber

## Mechanical face seals

Inner	Tungsten carbide/Carbon
Outer	Tungsten carbide/Tungsten carbide

## Weight

Total (excl. cable)	73 - 90 kg
---------------------	------------

## Options

Polyurethane-lined wear parts	POLY-LIFE®
Impeller (MT, HT)	Stainless steel
O-rings	Viton
Threaded house connection, starters, strainer for heavy contaminated water, various cable sizes, zinc anodes, protective ring for cable entrance cover	

## Accessories

Adapters, hose connections and other mechanical accessories. Electrical accessories such as pump controller, control panels, starters, monitoring relays.

Rating	* 3~	** 3~
Rated output	3.7 kW	5.5 kW
Speed of rotation	2800 rpm	2800 rpm



www.flygt.com  
www.xyleminc.com