



Classic Pumps Evolved To Perfection

FLYGT 2000 CLASSIC SERIES SUBMERSIBLE DEWATERING PUMPS

50 Hz

Tested In Reality For Over 50 Years

Built on a 50-year heritage, the Flygt 2000 series pump is a true classic. And like a classic, it stands the test of time. As we build on this heritage, we continue to improve the original design to produce some of the world's toughest pumps.

2071
Page 5

2125
Page 5



Flygt, a Xylem brand, is synonymous with engineering excellence, reliability and closeness to customers. Flygt is a world-leader in the design and manufacture of dry and submersible pumps, mixers and related intelligent controls systems. Product development and manufacturing of Flygt products is based in Sweden.

Reliability is a beautiful word. And the iconic Flygt 2000 classic series dewatering pumps have mastered the art to perfection. They're pumps made to last: a broad range of dependable pumps for virtually every challenge imaginable.

The 2000 classic series aluminum pumps help you to mobilize your resources in any given situation.

The steadfast cast iron pumps, featuring

· ORIGINAL ·



explosion-proof versions, help you protect your assets if/when necessary.

And the corrosion-resistant stainless steel pumps help you defend your investment even in the toughest environments.

The Flygt 2000 classic series pumps are made to cover all applications. And we're still paying homage to the tradition in the best way we know. By continuing to improve upon it.

2190

Page 6

2201

Page 7

2400

Page 11 & 15

2400 Duplex

Page 11 & 15

2250

Page 5



Lightweight Aluminum. Mobilizing Your Resources.

The 2000 classic series aluminum pumps are ready to adapt to virtually every environment and working condition. Models range from classic pump-design and traditional drainage pumps to slim pumps - ideal for all types of dewatering. Their versatility, robustness and mobility make them a natural-born dewatering multi-performer.

**All-purpose
and proven**

You'll find the 2000 classic series aluminum pumps in all areas of operations. They are typically used in mining/quarrying, construction, industrial or municipal applications.

A Loyal Companion

Tough dewatering pumps with outer casing and stator housing made in light-weight aluminum. They're versatile, enduring and widely applied in all types of dewatering. And like all pumps in the 2000 classic series, they share design features that bring reliability and robustness to a higher level.

Proven in all types of dewatering applications. »

Double mechanical shaft seal

Dual sealing for double security. Hard WCCR (Tungsten carbide) or RSiC (Silicon carbide) as an option. RSiC offers good thermal properties, excellent chemical resistance and resistance against sea water.

Hard-Iron™ impeller

Specially designed impeller with high chromium content for superb wear resistance (60 HRC). Longer operation – less maintenance.

Spin-Out™

Protects seal by expelling abrasive particles from the seal chamber, extending service life.

Wear-part protection

All major components subject to wear coated with PU (PolyLife™ polyurethane) or NBR (nitrile rubber) for wear resistance.

Adjustable diffusor

Easy hydraulic fine-tuning of a worn impeller.



2250

2250.011 HT/MT

Classic stable Flygt pump design. For high performance and big drainage jobs.

Durability & Mobility Combined

Portable and robust aluminum pumps with proven design for performance under harsh conditions.

Common features include:

- External oil and inspection plugs. Aecessibility and reliability combined. Longer service intervals.
- Wear-resistant semi-open impeller options.

(See page 18 for all available options.)

Stable and wear-resistant pumps for dewatering building yards and mines, draining water in flooded areas, and other similar applications. These pumps have a high performance-weight ratio and can handle water containing abrasive particles.



2071

2071.010 LT/MT

Light-weight pumps ideal for active dewatering. Slim design for confined spaces. Dual-stage option (MT).



2125

2125.181 HT

Traditional drainage pump. Combines high performance and low weight. Stainless steel impeller option.

New But Classic

The Flygt 2000 classic series is built on proven pump technology dating back to the 1960s. New models, like the Flygt 2190, share the same classic profile and inner workings as their robust and reliable siblings.

A new Flygt classic that goes all out when it comes to performance.»

Active Seal™

Unique zero-leakage sealing solution. A patented double mechanical seal system that minimizes downtime and maintenance and extends pump life.

Dura-Spin™

Closed impeller option. The unique, easy adjustable impeller and the suction cover with Dura-Spin grooves work together sweeping abrasive particles away from the impeller neck. Significantly increases hydraulic wear resistance.

Semi-open impeller option

Wear-resistant semi-open impeller in Hard-Iron or stainless steel.

Reinforced cable entry

Sturdier-than-ever. Ensures safe continuous operation.



A Familiar Profile With More Character

True to its heritage, it is designed for harsh environments and adds state-of-the-art features that make downtime a thing of the past.

Classic robustness inside and out:

- Double mechanical WCCR (Active Seal) or RSiC shaft seals
- External oil and inspection plugs
- Hard-Iron, PU and NBR wear parts
- Conical trim sleeve for easy impeller adjustment

(See page 18 for all available options.)

Tough and strong, the Flygt 2190 is ideal for applications in which the water or liquid contains high amounts of clay, stone chips, drilling fines etc, or to pump heavy sediment from tanks, sumps and containers.

2190

2190.010 HT

Mid-sized submersible drainage pump. Built for high head pumping with wear-resistant closed or semi-open impeller options.



The unique Dura-Spin impeller and suction cover. With three times more hydraulic wear resistance.

Semi-open wear-resistant impeller with swept-back vanes. Prevents string solids obstruction.

When it comes to the Flygt 2201, some things never change. Tough enough to handle whatever comes their way, these proven pumps have new features that can carry your operations far into the future.

A tried-and-true dewatering pump reaches new heights.»

1 Class H motor

Renowned Flygt design and manufacture for submersible use. Highly efficient to reduce generated heat, enabling dry-run capacity.

2 External oil and inspection plugs

Quick service check, less downtime, no unnecessary disassembly. A signature feature for Flygt pumps.

3 Dual-stage hydraulics

A two-stage design with double adjustable impellers (closed channel), enables pumping at unusually high heads (up to 140 m).

4 Conical trim sleeve

This fast and easy one-screw impeller-adjustment feature restores impeller to suction cover clearance to near-original condition. A feature shared with the Flygt 2190.

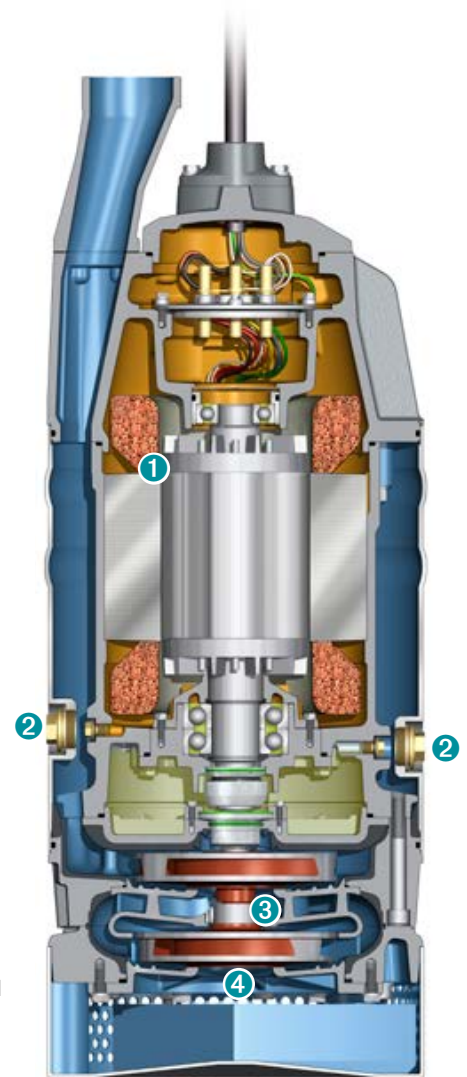

(2201.012 SH)

As Rugged & Durable As Ever

Authentic in every detail, all Flygt 2201 pumps have the same tough character, inside and out.

Also featuring:

- Double mechanical shaft seals, Active Seal and sturdy cabling
- Closed/semi-open hydraulics, Hard-Iron and stainless steel impeller options
- High-durability wear-parts

(See page 18 for all available options.)

The 2201 pumps are as reliable as ever, built to endure tough liquids with fines, rock, sand, clay, sediments or other abrasives. Added hydraulic features provides further versatility for construction and mining duties.



2201

2201.020 LT

Purpose-designed for high flow rate capability.

2201

2201.012 HT/MT

Durable and versatile pumping at high or medium heads.

2201

2201.012 SH

A two-stage hydraulic pump for super-high heads.

Facts & Figures

Performance

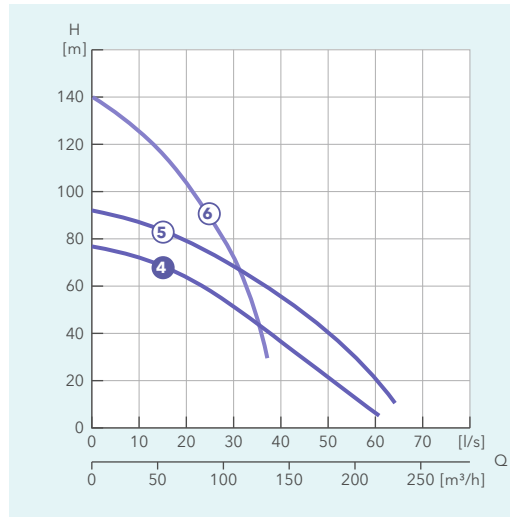
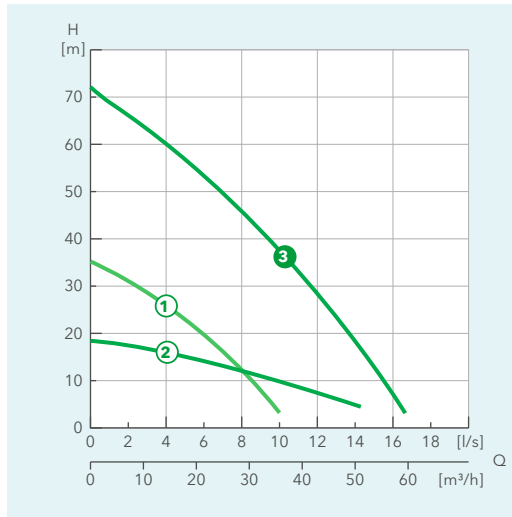

- 2071.010
 ① 231 MT
 ② 211 LT
 2125.181
 ③ 233 HT

- 2190.010
 ④ 259 HT
 2201.012
 ⑤ 259 HT
 ⑥ 276 SH

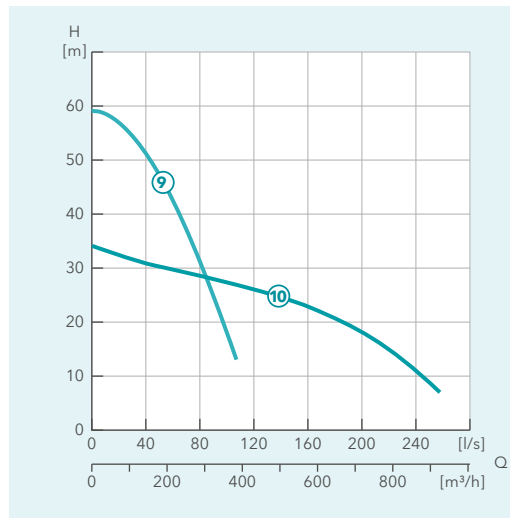
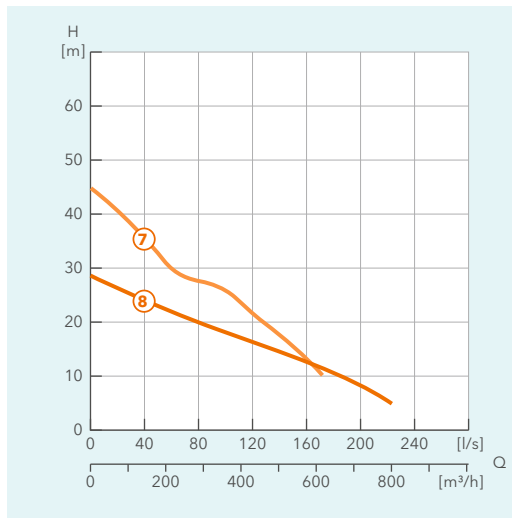

- 2201.012/020
 ⑦ 234 MT
 ⑧ 411 LT

- 2250.011
 ⑨ 433 HT
 ⑩ 431 MT

HT= High head, LT= High flow
 MT= Medium head
 SH= Super-high head

Composite curves for comparison purpose only. Consult engineering data for exact flow and head capabilities.

Specifications

Model	2071.010	2125.181	2190.010	2201.012	2201.012	2201.012	2201.020	2250.011	2250.011
(Config.)	MT/LT	HT	HT	HT	SH	MT	LT	MT	HT
Rating [kW]	3	8	25	37	37	37	30	54	54
Voltage [V/phase]	400, 3~	400, 3~	400, 3~	400, 3~	400, 3~	400, 3~	400, 3~	400, 3~	400, 3~
Rated current [A]	6.2	15	43	65	65	65	61	104	104
Weight [kg]	28	80	210	240	270	285	285	540	540
Max. height [mm]	705	830	1050	1046	1148	1332	1332	1260	1260
Max. width [mm]	185	465	430	430	430	500	500	940	860
Discharge Ø [in]	3"	3"	4"	4"	4"	6" & 8"	6" & 8"	10"	6"
Strainer hole [mm]	8×50	6×50	Ø 12	Ø 12	Ø 12	Ø 15	Ø 15	15×45	15×45
pH of pumped liquid	pH 5-8	pH 5-8	pH 5-8	pH 5-8	pH 5-8	pH 5-8	pH 5-8	pH 5-8	pH 5-8

With reservation for changes. For additional specifications, see product technical documentation.



Explosion-Proof. Approved To Protect Your Assets.

Don't take chances, protect your jobsite with explosion-proof pumps. This ability is a necessity in many industrial applications where protection or isolation from ignition sources is crucial. These heavyweights of dewatering also make for exceptionally reliable pumps. Ideal for heavy workloads in demanding environments, like mining or construction site operations.

**Durable
and secure**

2000 classic series cast iron/explosion-proof pumps, made to handle any dewatering challenge in open-pit or underground mines and quarries, despite the difficult and demanding nature of these environments.

A Reliable Partner

All explosion-proofed Flygt pumps are designed to operate safe in potentially hazardous areas. The 2000 classic series cast iron pumps feature models approved for both mines and hazardous gas areas for several markets. A necessity in many industrial applications.

Dependable,
hard-wearing and
highly versatile.»

Cast iron

Cast iron make for extremely robust and reliable pumps, tough enough to handle both abrasives-laden liquids and water containing chlorides.

Ex version

Explosion-proof. Constructed with safe electrical enclosure according to a specified temperature class. Certified compliance with the ATEX directive, meeting Essential Health and Safety Regulations (EHSR).

Dura-Spin or Semi-open impeller

Hydraulic wear-resistant options include the unique, highly efficient Dura-Spin closed impeller with suction cover and the Semi-open impeller. (See page 6.)

Hot liquid capability

Some models are available in versions handling liquid temp. of up to 70° and 90°C (158° and 194°F).



2201
2201.321 HT/MT

A truly hard-wearing and versatile pump, designed to efficiently handle tough liquids.

Ex version 2201.692



2201
2201.321 SH

A two-stage hydraulic pump with double adjustable impellers for super-high heads.

Ex version 2201.692SH

A Powerful Combination

Persistent and powerful performers; steady cast iron pumps for heavy workloads, commonly found in mining applications.

Shared features include:

- Double mechanical WCCR shaft seal (optional RSiC for extra acidic resistance)
- Hydraulic versatility including semi-open, Hard-Iron, stainless steel and dual-stage (double) impeller options
- PU and NBR wear-parts
- Spin-Out and adjustable diffusor

(See page 18 for all available options.)



2075
2075.324 HT/MT/ST

Proven robust design with hydraulic options for flexible and reliable dewatering.

MSHA 2075.590
Ex version 2075.690



2125
2125.320 HT/MT/SH*

Traditional Flygt drainage pump. Sturdy design renowned for handling tough jobs.

MSHA 2125.590
Ex version 2125.690
*SH available for 2125.690 only.



2400
2400.402 HT/MT

Iconic mine dewatering pump. Top-performing and ample with material options.

MSHA 2400.490
Ex version 2400.591



Ex certified



Mine Safety & Health Administration
product approval

Facts & Figures

Performance

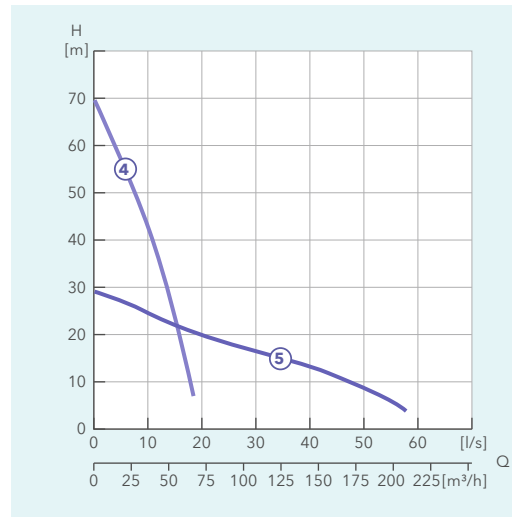
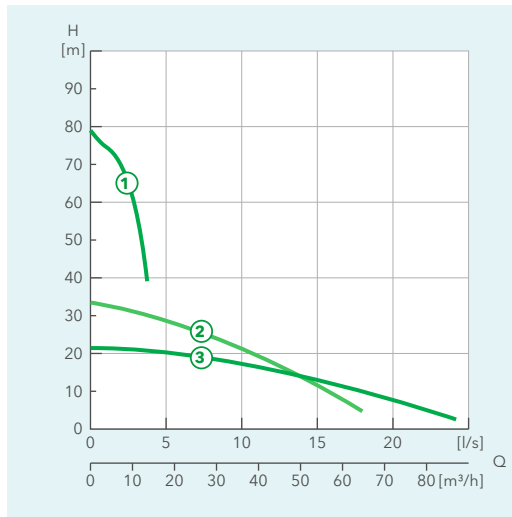

2075.324

- ① 271 ST
- ② 233 HT
- ③ 231 MT

2125.320

- ④ 233 HT
- ⑤ 231 MT

B = Semi-open impeller
 HT = High head
 MT = Medium head
 SH/ST = Dual-stage high head

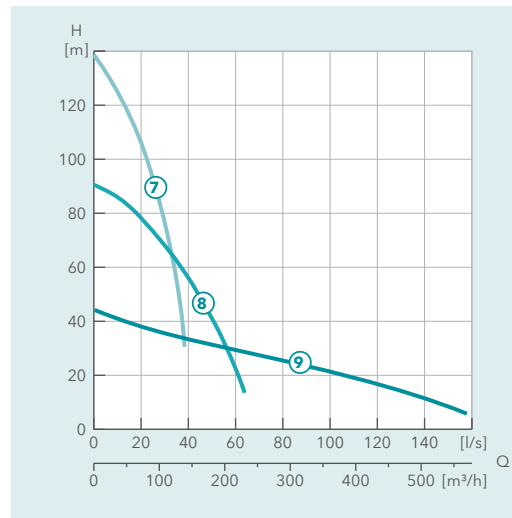
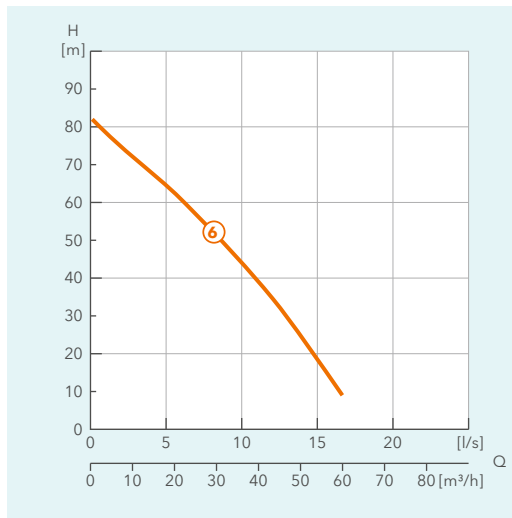

2125.690

- ⑥ 253 SH

2201.321

- ⑦ 276 SH
- ⑧ 259 HT
- ⑨ 234 MT

2400.402

See page 16 for performance and specifications.

Composite curves for comparison purpose only. Consult engineering data for exact flow and head capabilities.

Specifications

Model	2075.324	2075.324	2075.324	2125.320	2125.320	2125.690	2201.321	2201.321	2201.321	2400.420
(Config.)	MT	HT	ST	MT	HT	SH	MT	HT	SH	See page 16
Rating [kW]	3.7	3.7	5.5	8	8	9.7	37	37	37	
Voltage [V/phase]	400, 3~	400, 3~	400, 3~	400, 3~	400, 3~	500	400, 3~	400, 3~	400, 3~	
Rated current [A]	7.1	7.1	11	15	15	16	65	65	65	
Weight [kg]	73	73	90	150	164	164	445	350	395	
Max. height [mm]	565	565	575	830	830	830	1151	1048	1150	
Max. width [mm]	445	445	410	485	465	465	500	436	436	
Discharge Ø [in]	4"	3"	4"	4"	3"	3"	8"	4"	4"	
Strainer hole [mm]	8×8	8×8	6×6	6×50	6×50	6×50	Ø 15	Ø 12	Ø 12	
pH of pumped liquid	pH 5-8	pH 5-8	pH 5-8	pH 5-8	pH 5-8	pH 5-8	pH 6-11	pH 6-11	pH 6-11	
Warm liquid, 70°C	•	•	• (90°C)	-	-	-	-	-	-	
Ex/MSHA version	•	•	•	•	•	•	•	•	•	

With reservation for changes. For additional specifications, see product technical documentation.



Resistant. Defending Your Investment.

Corrosion is a relentless enemy. For pumps that are tasked to handle liquids with extreme pH levels, it can lead to devastating results. It is one of the toughest water transport challenges and call for something tougher, easier and more cost-effective to maintain than aluminum, cast iron or protective coatings.

That's why the Flygt 2000 classic series has adapted to dewatering applications in corrosive environments, as part of Xylem's broad range of pumps for a wide variety of needs and applications.

Forceful and unyielding

2000 classic series high-performance pumps for open pit and underground mines where pumped media have low or unpredictable pH value. Or industrial applications/sites where pumps must endure acidic, contaminated, corrosive and/or abrasive liquids.

A Powerful Ally

The Flygt 2400 has remained an iconic mine dewatering pump for more than 40 years. Now available in stainless steel, it can also handle advanced jobs where other pumps demonstrate inferior corrosion resistance.

Supreme durability and power for the toughest jobs.»

1 High-performance hydraulics

Dual stage hydraulics with double abrasion-resistant high chromium steel impellers for very high head pumping (HT). Semi-open impellers (MT) and stainless steel impeller material as option.

2 Easy impeller fine-tuning

Adjustable diffusor enables fast and easy performance trimming or upkeep.

3 Optimum wear-part protection

PU, NBR and stainless steel options.

Stainless through-and-through

The Duplex version is built for optimum corrosion resistance. Hydraulics, housings, casings, shaft and wear-parts are all made in Duplex structure stainless steel (AISI 329).

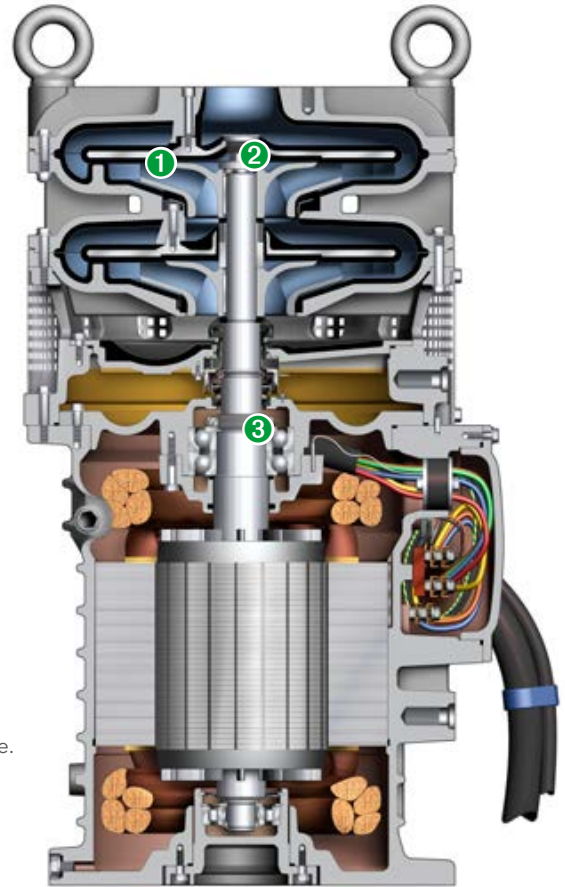

(2400.390 HT)

Top Performance For Deep Excavations

Compact heavy-duty pumps for very high heads, resistant to both abrasion and corrosion.

Cast iron version features high-chromium steel impellers for abrasion resistance.

The stainless steel design also withstands wide variances in pH level, enabling it to handle both acidic and abrasive media.

(See page 18 for all available options.)



2400

2400.402 HT/MT

Cast iron body and high-chromium steel impeller(s). Stainless steel impeller/hydraulic end as options.



2400 Duplex

2400.390 HT

An all stainless steel pump. Dual closed stainless steel impellers for high head.

2400.390 MT

Semi-open stainless steel impeller for high flow. Stainless steel stand for horizontal installment.

Built to last under tough operating conditions, such as in underground or open-pit mines. Ideal for pumping abrasive liquids containing sand or drilling fines, as well as corrosive liquids or liquids with chloride/salt content.

Facts & Figures

Performance

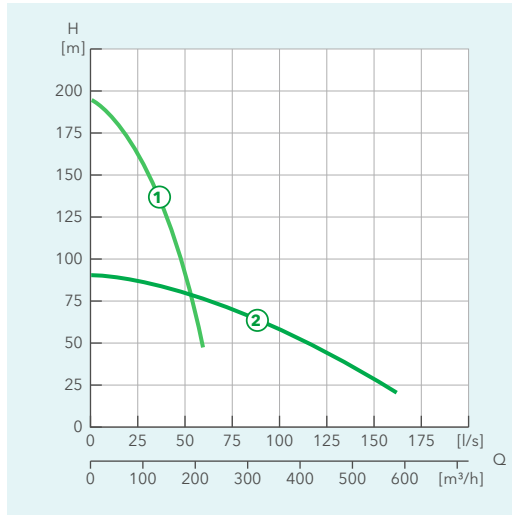

2400.402

- ① 243 HT
- ② 231 MT

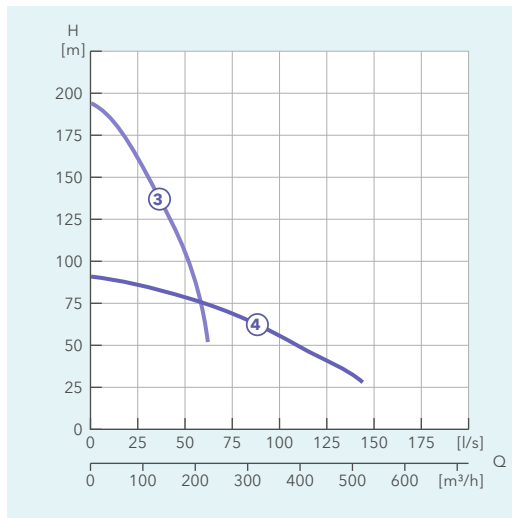

2400.390 Duplex

- ③ 263 HT
- ④ 251 MT

HT= High head
MT= Medium head

Composite curves for comparison purpose only. Consult engineering data for exact flow and head capabilities.

Specifications

Model	2400.402	2400.402	2400.390	2400.390
(Config.)	MT	HT	MT	HT
Rating [kW]	90	90	85	85
Voltage [V/phase]	400, 3~	400, 3~	400, 3~	400, 3~
Rated current [A]	148	148	141	141
Weight [kg]	900	985	925	1015
Max. height [mm]	1180	1145	1180	1145
Max. width [mm]	770	770	740	700
Discharge Ø [in]	6"	4"	6"	4"
Strainer hole [mm]	10×10	10×10	10×10	10×10
pH of pumped liquid	pH 5-8	pH 5-8	pH 2-10	pH 2-10
Warm liquid, 70°C	-	-	-	-
Ex/MSHA version	•	•	-	-

With reservation for changes. For additional specifications, see product technical documentation.





Boosting Performance & Versatility

Options & Accessories

Model	2071	2075	2125	2125	2190	2201	2201	2201	2250	2400	2400
Version	2071.010	2075.324	2125.181	2125.320	2190.010	2201.012	2201.020	2201.321	2250.011	2400.402	2400.390
Options											
External oil & inspection plugs	•	•	•	•	•	•	•	•	•	•	•
SUBCAB® submersible cables	•	•	•	•	•	•	•	•	•	•	•
Impeller options											
Closed impeller					•	◦		◦		◦	◦
Semi-open impeller	•	•	•	•	•	•	•	•	•	◦	◦
Dual stage double impellers	◦	◦	◦			◦		◦		◦	◦
Hard-Iron impeller	•	•	•	•	•	•	•	•	•	•	
Stainless steel impeller	◦	•	•	•	•	•		•		•	•
Hydraulic options											
Dura-Spin					◦	◦		◦			
Spin-Out		•	•	•	•	•	•	•	•	•	•
Ajustable diffuser	•	•	•	•	•		•		•	•	•
Conical trim sleeve					•	•		•			
Wear part protection											
Poly-Life polyurethane	•	•	•		•	•	•	•	•	•	
Nitrile rubber	•	•	•	•	•	•		•	•	•	•
Hard-Iron					◦	◦		◦			
Stainless steel										•	•
Seal Options											
Double WCCR shaft seal	•	•	•	•	•	•	•	•	•	•	
Outer seal: Silicone carbide (RSiC)					•	•		•		•	•
Active Seal					•	•	•	•	•	•	•
Mechanical accessories											
Tandem connection	•		•	•	•	•	•	•	•		
Zinc anode protection						•		•			
Pump floatation raft			•	•	•	•	•	•	•	•	•
Electrical accessories											
Starters manual/automatic	•	•	•	•	•	•	•	•	•	•	•
FPC 100™ pump control	•	•	•	•	•	•	•	•	•	•	•
PIM™ pump integrated memory	•	•	•	•	•	•	•	•	•	◦	◦

• = Standard • = Available option ◦ = Available depending on configuration (HT/MT etc.) See product technical documentation for details.

The 2000 classic series pumps are easily adaptable to specific requirements thanks to the wide range of accessories.



◀ Complete pump raft module including lifting equipment and pump bracket.



◀ The Flygt tandem connection connects two or more pumps in series for extra high-head operation.

The Flygt zinc anode kits provide extra protection against galvanic corrosion for all metal parts. ▶



A Forceful Supporter All The Way

Xylem Dewatering Offer

Whatever your dewatering challenge, we've got the solution for you. Sludge, slurry, big pumps, small pumps, electrical or diesel driven, corrosive abrasive particles or high pH levels, we have the pump that matches your requirements with a reliability and performance second to none. From the classic Flygt 2000 to the light-weight Ready, the sturdy Flygt 5000 to the independently-powered Godwin, no other company covers the full spectrum of dewatering needs like Xylem. We've got your back!

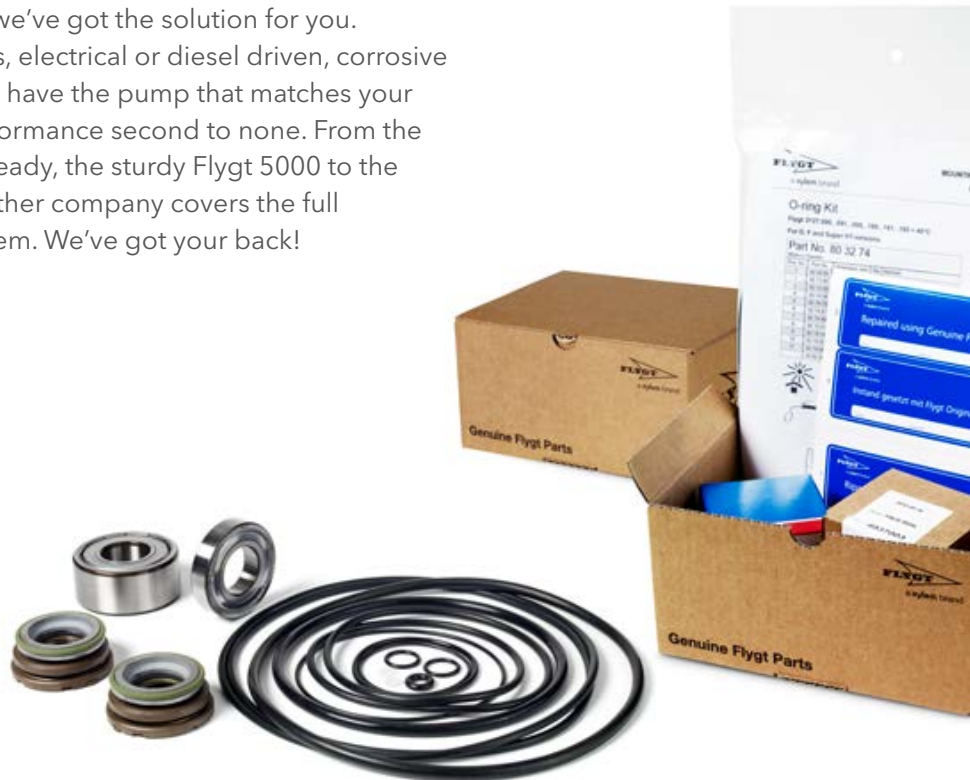

Rental & onsite services

As the global leader in large-scale engineered water technology projects, Xylem Rental Solutions designs, builds, and operates scalable, turnkey systems that help cities and industries solve complex, challenging water problems.

Whether you require fast-track temporary emergency response or reliable, cost-effective long-term operation, the breadth of our fleet and the depth of our expertise help our customers meet their water challenges with greater efficiency, reliability, and peace of mind.

With Xylem Rental Solutions you get solid engineering advice and electric, diesel and explosion-proof rental equipment for emergency, temporary bypass or semi-permanent pumping of water and wastewater. Services include dewatering, bypass pumping, try-before-you-buy, and longterm rental and maintenance.

Repair kits

Product-specific repair kits are available for most of our pumps. By using our kits you ensure that you restore the original optimal performance and quality of your pump.

SIMPLER HANDLING

One package means easier storage and easier physical handling. One part number simplifies the order process.

TIME SAVINGS

All parts in one box means reduced administration time and removes the risk of having to wait for part deliveries because you do not have all parts needed for the repair available. Simplified logistics also saves time.

LOWER COSTS

You get lower handling and administration costs and a lower price per item compared to separate purchase of parts.

Xylem Total Care

Xylem TotalCare is a comprehensive, integrated portfolio of services designed to ensure that your water and wastewater equipment keeps running at its best.

Our team of knowledgeable and highly skilled experts specializes in all types of dewatering applications, such as drainage, slurry and well-pointing. We take pride in our ability to help customers overcome challenges and optimize operations by providing the right solution every time. Our service network spans 150 countries with Xylem workshops and trusted service partners that can support you with application engineering, maintenance, pump repair, spare parts, turnkey project management, and more.

Find out more about services at xylem.com → Products & Services → Services

Xylem ['zīləm]

- 1) The tissue in plants that brings water upward from the roots;
- 2) a leading global water technology company.

We're a global team unified in a common purpose: creating advanced technology solutions to the world's water challenges. Developing new technologies that will improve the way water is used, conserved, and re-used in the future is central to our work. Our products and services move, treat, analyze, monitor and return water to the environment, in public utility, industrial, residential and commercial building services settings. Xylem also provides a leading portfolio of smart metering, network technologies and advanced analytics solutions for water, electric and gas utilities. In more than 150 countries, we have strong, long-standing relationships with customers who know us for our powerful combination of leading product brands and applications expertise with a strong focus on developing comprehensive, sustainable solutions.

For more information on how Xylem can help you, go to www.xylem.com



www.xylem.com